

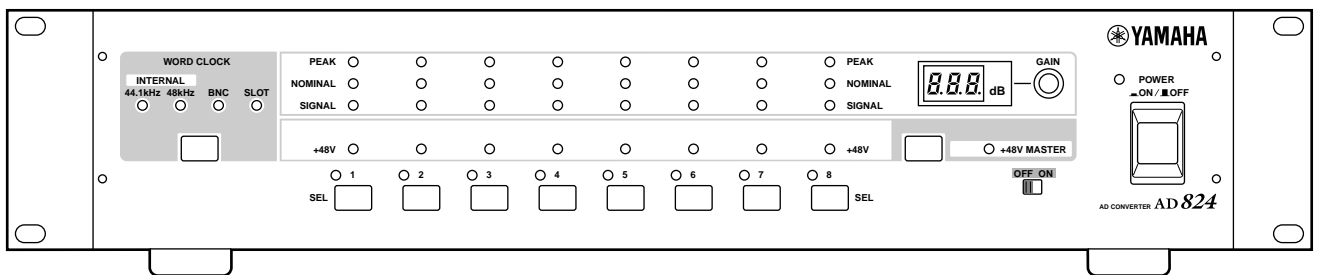

AD CONVERTER

AD 824

Owner's Manual



Keep This Manual For Future Reference.



FCC INFORMATION (U.S.A.)

1. **IMPORTANT NOTICE: DO NOT MODIFY THIS UNIT!** This product, when installed as indicated in the instructions contained in this manual, meets FCC requirements. Modifications not expressly approved by Yamaha may void your authority, granted by the FCC, to use the product.
2. **IMPORTANT:** When connecting this product to accessories and/or another product use only high quality shielded cables. Cable/s supplied with this product **MUST** be used. Follow all installation instructions. Failure to follow instructions could void your FCC authorization to use this product in the USA.
3. **NOTE:** This product has been tested and found to comply with the requirements listed in FCC Regulations, Part 15 for Class "B" digital devices. Compliance with these requirements provides a reasonable level of assurance that your use of this product in a residential environment will not result in harmful interference with other electronic devices. This equipment generates/uses radio frequencies and, if not installed and used according to the instructions found in the users manual, may cause interference harmful to the operation of other electronic devices. Compliance with FCC regulations does not guarantee that interference will not occur in all installations. If this product is found to be the source of interference, which can be determined by turning the unit "OFF" and "ON", please try to eliminate the problem by using one of the following measures: Relocate either this product or the device that is being affected by the interference. Utilize power outlets that are on different branch (circuit breaker or fuse) circuits or install AC line filter/s. In the case of radio or TV interference, relocate/reorient the antenna. If the antenna lead-in is 300 ohm ribbon lead, change the lead-in to coaxial type cable. If these corrective measures do not produce satisfactory results, please contact the local retailer authorized to distribute this type of product. If you can not locate the appropriate retailer, please contact Yamaha Corporation of America, Electronic Service Division, 6600 Orangethorpe Ave, Buena Park, CA 90620

The above statements apply **ONLY** to those products distributed by Yamaha Corporation of America or its subsidiaries.

WARNING: THIS APPARATUS MUST BE EARTHED

IMPORTANT

THE WIRES IN THIS MAINS LEAD ARE COLOURED IN ACCORDANCE WITH THE FOLLOWING CODE:

GREEN-AND-YELLOW :	EARTH
BLUE :	NEUTRAL
BROWN :	LIVE

As the colours of the wires in the mains lead of this apparatus may not correspond with the coloured markings identifying the terminals in your plug, proceed as follows:

The wire which is coloured GREEN and YELLOW must be connected to the terminal in the plug which is marked by the letter E or by the safety earth symbol \perp or coloured GREEN and YELLOW.

The wire which is coloured BLUE must be connected to the terminal which is marked with the letter N or coloured BLACK.

The wire which is coloured BROWN must be connected to the terminal which is marked with the letter L or coloured RED.

ADVARSEL!

Lithiumbatteri—Eksplodingsfare ved fejlagtig håndtering. Udskiftning må kun ske med batteri af samme fabrikat og type. Levér det brugte batteri tilbage til leverandoren.

VARNING

Explosionsfara vid felaktigt batteribyte. Använd samma batterityp eller en ekvivalent typ som rekommenderas av apparattillverkaren. Kassera använt batteri enligt fabrikantens instruktion.

VAROITUS

Paristo voi räjähtää, jos se on virheellisesti asennettu. Vaihda paristo ainoastaan laitevalmistajan suosittelemaan tyyppiin. Hävitä käytetty paristo valmistajan ohjeiden mukaisesti.

* This applies only to products distributed by YAMAHA KEMBLE MUSIC (U.K.) LTD.

NEDERLAND

- Dit apparaat bevat een lithium batterij voor geheugen back-up.
- Raadpleeg uw leverancier over de verwijdering van de batterij op het moment dat u het apparaat aan het einde van de levensduur afdankt of de volgende Yamaha Service Afdeling:
Yamaha Music Nederland Service Afdeling
Kanaalweg 18-G, 3526 KL UTRECHT
Tel. 030-2828425
- Gooi de batterij niet weg, maar lever hem in als KCA.

THE NETHERLANDS

- This apparatus contains a lithium battery for memory back-up.
- For the removal of the battery at the moment of the disposal at the end of the service life please consult your retailer or Yamaha Service Center as follows:
Yamaha Music Nederland Service Center
Address: Kanaalweg 18-G, 3526 KL
UTRECHT
Tel: 030-2828425
- Do not throw away the battery. Instead, hand it in as small chemical waste.

Important Information

Please read the following before using the AD824

Warnings

- Do not subject the AD824 to extreme temperatures, humidity, direct sunlight, or dust, which could be a potential fire or electrical shock hazard.
- Do not allow water to enter the AD824 or allow it to become wet. Fire or electrical shock may result.
- Connect the power cord only to an AC outlet of the type stated in this *Owner's Manual* or as marked on the AD824. Failure to do so is a fire and electrical shock hazard.
- Hold the power-cord plug when disconnecting from an AC outlet. Never pull the cord. A power cord damaged through pulling is a potential fire and electrical shock hazard.
- Do not touch the power plug with wet hands. Doing so is a potential electrical shock hazard.
- Do not place heavy objects, including the AD824, on top of the power cord. A damaged power cord is a fire and electrical shock hazard. In particular, be careful not to place heavy objects on a power cord covered by a carpet.
- Do not scratch, bend, twist, pull, or heat the power cord. A damaged power cord is a fire and electrical shock hazard.
- If the power cord is damaged (e.g., cut or a bare wire is exposed), ask your dealer for a replacement. Using the AD824 with a damaged power cord is a fire and electrical shock hazard.
- Do not plug several devices into the same AC outlet. This may overload the AC outlet, and could be a fire or electrical shock hazard. It may also affect the performance of some equipment.
- If you notice any abnormality, such as smoke, odor, or noise, or if a foreign object or liquid gets inside the AD824, turn it off immediately. Remove the power cord from the AC outlet and consult your dealer for repair. Using the AD824 in this condition is a fire and electrical shock hazard.
- Do not place small objects on top of the AD824. Metal objects falling inside the AD824 is a fire and electrical shock hazard.
- If a foreign object or water gets inside the AD824, turn it off immediately. Remove the power cord from the AC outlet and consult your dealer for repair. Using the AD824 in this condition is a potential fire and electrical shock hazard.
- Should the AD824 be dropped or the cabinet be damaged, turn off the power, remove the power plug from the AC outlet, and contact your dealer. If you continue using the unit without heeding this instruction, fire or electrical shock may result.
- Do not remove the AD824's cover. You could receive an electrical shock. If you think internal inspection, maintenance, or repair is necessary, contact your dealer.
- Do not attempt to modify the AD824. This is a potential fire and electrical shock hazard.
- Do not block the AD824 ventilation slots. Blocking the ventilation slots is a potential fire hazard.

Cautions

- Allow enough free space around the unit for normal ventilation. This should be: 10 cm at the sides, 15 cm behind, and 30 cm above. These distances should also be adopted when rack-mounting the AD824. For normal ventilation during use, remove the rear of the rack or open a ventilation hole. If the airflow is not adequate, the AD824 will heat up inside and may cause a fire.
- Use the AD824 in an environment with a temperature of between 10°C and 35°C (50°F and 95°F).
- Turn off all equipment before connecting it to the AD824, and use only the cables specified in the relevant owner's manuals.
- If you plan not to use the AD824 for a long period of time, remove the power cord from the AC outlet. Leaving the AD824 connected is a potential fire hazard.
- Do not use benzene, thinner, cleaning detergent, or a chemical cloth to clean the AD824. Use only a soft, dry cloth.
- If the AD824 is stored in a cold place (e.g., overnight in a car), and then moved to a warmer environment, or the temperature rises sharply, condensation may form inside the AD824, which may affect performance. In such cases, the AD824 should be allowed to acclimatize for about one hour before use.
- When the wordclock source is changed on the wordclock master device (e.g., this AD824, a DME32 or 02R), noise may occur from the outputs of the wordclock slave devices, especially a AD824 with an MY8-AT I/O card installed, so turn down your power amps beforehand, otherwise any connected speakers may be damaged.
- If the error code "E1" or "E3" appears on the GAIN display when the AD824 is turned on, see your dealer about changing the internal backup battery. Although the AD824 will work even when the battery voltage is low, it may not remember the current settings next time it's turned on.

Interference

The AD824 uses high-frequency digital circuits that may cause interference on radio and television equipment located nearby. If interference is a problem, relocate the affected equipment.

AD824 Exclusion of Certain Responsibility

Manufacturer, importer, or dealer shall not be liable for any incidental damages including personal injury or any other damage caused by improper use or operation of the AD824.

Yamaha cannot be held responsible for any loss of data or data damage due to improper use or operation of the AD824.

Package Contents

The AD824 package should contain the following items. Contact your Yamaha dealer if anything is missing.

- AD824 AD Converter
- 9-pin D-sub crossed cable (1.5 m)
- This manual

Trademarks

ADAT MultiChannel Optical Digital Interface is a trademark of Alesis Corporation. Tascam Digital Interface is a trademark and Tascam and Teac are registered trademarks of Teac Corporation. Yamaha is a trademark of Yamaha Corporation. All other trademarks are the property of their respective holders and are hereby acknowledged.

Copyright

No part of the AD824 software or this *Owner's Manual* may be reproduced or distributed in any form or by any means without the prior written authorization of Yamaha Corporation.

© 2000 Yamaha Corporation. All rights reserved.

Contents

1	Introduction	1
	Welcome	1
	Installation	1
	Connecting the Power Cord	1
	Turning On the Power	1
2	Touring the AD824	2
	Front Panel	2
	Rear Panel	3
3	Operation	5
	Selecting the Wordclock Source	5
	Setting the Phantom Power for Each Channel	5
	Setting the +48V Phantom Power Master	6
	Setting the Gain	6
	Controlling the AD824 Remotely	6
4	Digital I/O Cards	7
	About Digital I/O Cards	7
	Card Specifications	7
	Installing I/O Cards	8
5	Hookup Examples	9
	Basic AES/EBU Connection	9
	Basic ADAT Connection	9
	AES/EBU Connection with Splitter Cable	10
	Dual ADAT Connection	10
	Insert Connection	11
	Personal Computer Connection	11
	Yamaha DME32 Connection	12
	Multiple AD824 Connection	13
6	Wordclocks	14
	About Wordclocks	14
	Wordclock Hookup Examples	14
	Wordclock Termination	15
	Appendix	16
	Error Messages	16
	Specifications	16
	Dimensions	18

1 Introduction

Welcome

Thank you for choosing the Yamaha AD824 AD Converter. The AD824 is a high-performance 8-channel analog-to-digital converter, with 24-bit linear analog-to-digital converters and 128-times oversampling, providing a typical dynamic range of 110 dB. Optional mini YGDAI (Yamaha General Digital Audio Interface) cards offer a variety of digital output interfaces, with support for all the popular digital audio interconnect formats, including AES/EBU, ADAT, and Tascam TDIF-1.

Analog inputs feature electronically balanced XLRs, high-quality mic preamps, independently switchable 48-volt phantom powering, and rotary gain adjustment. Inputs can be used with either microphones or line-level sources. Analog outboard equipment can be patched into each channel by using the electronically-balanced analog insert points on two 1/4" TRS phone jacks.

Remote control from a Yamaha DME32, personal computer, or other device is possible using an exclusive control protocol.

Installation

The AD824 can be used freestanding on a stable surface, somewhere that complies with the important information at the beginning of this manual, or mounted in a rack.

When mounting the AD824 in a rack, leave adequate ventilation space around the AD824 (at least 10 cm of free space behind). If the AD824 is mounted in a portable rack case, keep the rear of the case open when using the AD824 so as not to obstruct the flow of air from the air vents. Do not mount the AD824 next to equipment that produces a lot of heat, such as a power amplifier.

Connecting the Power Cord

Warning: Turn off all equipment before making any connections.

Connect the power-cord plug to a suitable AC wall outlet, one that conforms to the power supply requirements stated on the AD824 rear panel.

Turning On the Power

To prevent audible thumps and clicks, turn on your audio equipment in the following order (reverse this order when turning off)—sound sources, AD824, mixer or recorder (e.g., 02R, DME32, D24, etc.), power amplifiers.

- 1 Press the [POWER] switch to turn on the AD824.
The AD824 starts up and the POWER indicator lights up.
- 2 Press the [POWER] switch again to turn off the AD824.
The POWER indicator goes out.

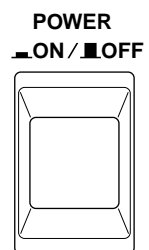

2 Touring the AD824

Front Panel

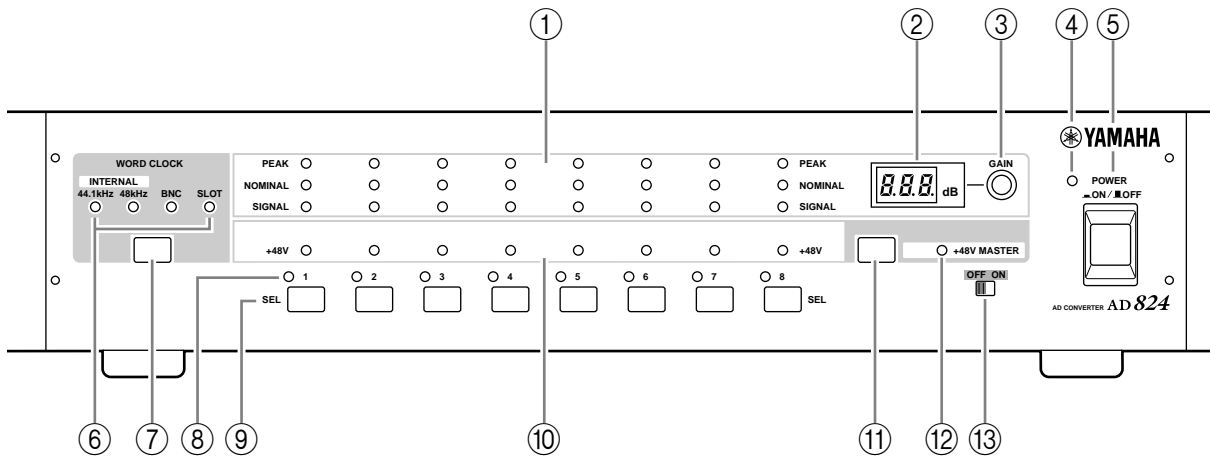

- ① **PEAK, NOMINAL & SIGNAL indicators**
These indicators show the signal level of each channel and light up as follows:
PEAK 3 dB below maximum input level.
NOMINAL 14 dB below maximum input level.
SIGNAL 34 dB below maximum input level.
- ② **GAIN display**
This 3-digit, 7-segment display shows the gain setting of the selected channel.
- ③ **GAIN control**
This rotary control is used to set the gain of the selected channel.
- ④ **POWER indicator**
This indicator lights up when the AD824 is powered up.
- ⑤ **POWER switch**
This switch is used to turn on the power to the AD824. See “Turning On the Power” on page 1 for more information.
- ⑥ **WORD CLOCK indicators**
These indicators show the selected wordclock source. When the AD824 cannot lock to the selected source, the corresponding indicator flashes.
- ⑦ **WORD CLOCK Source button**
This button is used to select the wordclock source: 44.1 kHz internal, 48 kHz internal, BNC, or SLOT.
- ⑧ **Channel SEL indicators**
These indicators show which channel is currently selected.
- ⑨ **Channel SEL buttons**
These buttons are used to select channels for use with the gain and +48V phantom power functions.

- ⑩ **Channel +48V indicators**
These indicators show whether the +48V phantom power is on or off for each channel.
- ⑪ **+48V on/off button**
This button is used to set the +48V phantom power for the selected channel.
- ⑫ **+48V MASTER indicator**
This indicator shows whether the MASTER +48V phantom power switch is on or off.
- ⑬ **+48V MASTER switch**
This switch is used to turn on and off the +48V phantom power master supply.

Security Cover

For certain applications you may wish to fit a protective cover over the AD824's GAIN controls and switches. Although Yamaha do not make such a cover, the AD824 has four fixing holes to affix a custom-made cover. If you fit such a cover, make sure that the fixing screws do not protrude inside the AD824 by more than 10 mm. The fixing holes accept M3-size machine screws, and are spaced 45.0 mm vertically, 410 mm horizontally.

Rear Panel

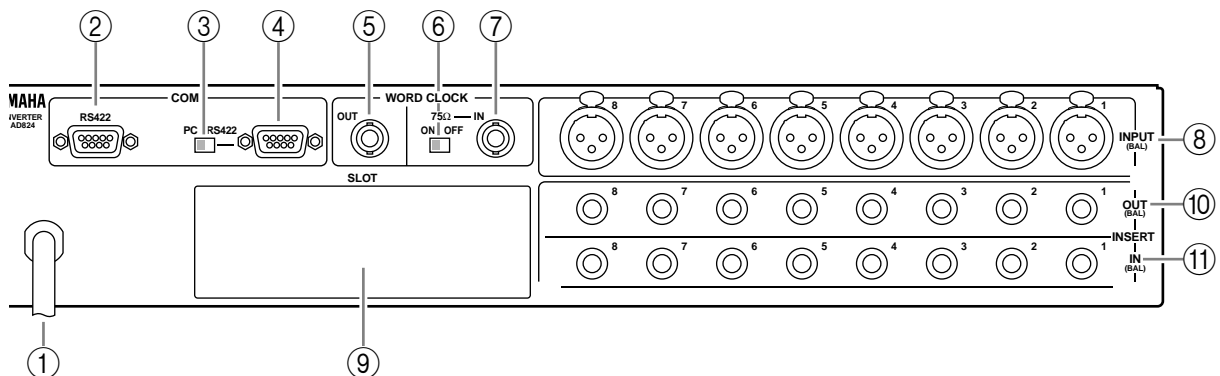

- ① **Power cable**
The power cable is used to connect the AD824 to an AC outlet. See “Connecting the Power Cord” on page 1 for more information.
- ② **COM RS422 port**
This 9-pin D-sub connector is used to connect the AD824 to the next AD824 in a multiple-unit system.
- ③ **COM PC/RS422 switch**
This switch should be set to RS422 when the COM PC/RS422 port is connected to a DME32 or the previous AD824 in a multiple-unit system, or PC when it's connected to a PC.

- ④ **COM PC/RS422 port**
This 9-pin D-sub connector is for connecting the AD824 to a device for remote control, such as a Yamaha DME32 or personal computer. It's also used to connect to the previous AD824 in a multiple-unit system.
- ⑤ **WORD CLOCK OUT connector**
This BNC connector transmits the wordclock signal.
- ⑥ **WORD CLOCK 75Ω ON/OFF switch**
This switch is used to terminate the wordclock signal received at the WORD CLOCK IN. See “Wordclocks” on page 14 for more information.
- ⑦ **WORD CLOCK IN connector**
This BNC connector is used to connect an external wordclock source. See “Wordclocks” on page 14 for more information.
- ⑧ **INPUT (BAL) connectors**
These female XLR-3-31-type connectors are the analog inputs. They're electronically balanced and are wired as follows: pin-1 ground, pin-2 hot (+), and pin-3 cold (-).

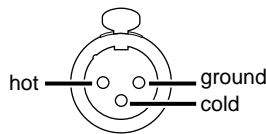

- ⑨ **SLOT**
This slot is for use with optional mini YGDAI cards, which offer various digital output options. See “Digital I/O Cards” on page 7 for more information.
- ⑩ **INSERT OUT (BAL) connectors**
These balanced 1/4" TRS phone jacks are the insert outputs, or send connectors. The insert point on each channel is located between the head amplifier and A/D converter. They're electronically balanced and are wired as follows: tip=hot, ring=cold, and sleeve=ground.

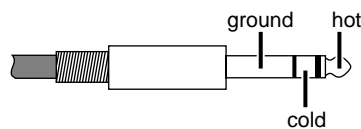

- ⑪ **INSERT IN (BAL) connectors**
These balanced 1/4" TRS phone jacks are the insert inputs, or return connectors. The insert point on each channel is located between the head amplifier and A/D converter. The signal level indicators are located after the INSERT IN connector. They're electronically balanced and are wired as follows: tip=hot, ring=cold, and sleeve=ground.

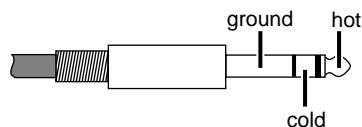

3 Operation

Selecting the Wordclock Source

The wordclock source can be set to 44.1 kHz internal, 48 kHz internal, BNC, or SLOT.

Note: When the wordclock source is changed on the wordclock master device (e.g., this AD824, a DME32 or 02R), noise may occur from the outputs of the wordclock slave devices, especially a AD824 with an MY8-ATI/O card installed, so turn down your power amps beforehand, otherwise any connected speakers may be damaged.

- 1 Use the [WORD CLOCK] button to select a source.
The corresponding wordclock indicator flashes quickly.
- 2 While the indicator is flashing, press the [WORD CLOCK] button again.
The wordclock source changes and the corresponding indicator stops flashing and lights up continuously. The indicator of previously selected wordclock source goes out. When the AD824 cannot lock to the selected wordclock source, the corresponding indicator flashes.

See page 14 for more information on wordclocks.

Setting the Phantom Power for Each Channel

The +48V phantom power can be turned on and off for each channel individually.

Note: In order to use the +48V phantom power the +48V MASTER switch must be in the ON position.

- 1 Use the [SEL] buttons to select a channel.
The selected channel's SEL indicator lights up.
- 2 Press the +48V on/off button.
The channel's +48V indicator flashes quickly.
- 3 While the indicator is flashing, press the [+48V] button again to turn the channel's +48V phantom power on or off.
The channel's +48V indicator lights up when the phantom power is on, and goes off when it's turned off.

Setting the +48V Phantom Power Master

The +48V phantom power for all channels can be turned on and off by using the +48V MASTER switch.

- 1 Set the +48V MASTER switch to the ON position to turn on the +48V phantom power master supply.

The +48V MASTER indicator lights up.

- 2 Set the +48V MASTER switch to the OFF position to turn off the +48V phantom power master supply.

The +48V MASTER indicator goes out.

Note that the channel +48V indicators remain lit when the +48V MASTER switch is set to the OFF position.

Setting the Gain

The head-amp gain for each channel can be set individually.

- 1 Use the [SEL] buttons to select a channel.

The selected channel's SEL indicator lights up and the gain setting appears on the GAIN display.

- 2 Use the GAIN control to set the gain.

The gain can be set in 6 dB steps.

Controlling the AD824 Remotely

Using an exclusive control protocol, the AD824 can be remotely controlled from a Yamaha DME32, personal computer, or other device connected to the COM PC/RS422 port. In addition, several AD824s can be remotely controlled by connecting them together in a chain-like fashion by using both the COM PC/RS422 port and the COM RS422 port.

When a control signal is detected, the GAIN display indicates the AD824's ID number, which is useful for identifying AD824s in a multiple-unit system. When an operation is next performed on the AD824, the ID number disappears. ID numbers are determined by the position of each AD824 in the connection chain and are set automatically.

The COM PC/RS422 switch should be set to RS422 when the COM PC/RS422 port is connected to a DME32 or the next AD824 in a multiple-unit system, or PC when it's connected to a PC.

Note: When connecting to an AD824's COM PC/RS422 port and COM RS422 port, be careful not to create a loop connection between them.

See "Personal Computer Connection" on page 11 and "Yamaha DME32 Connection" on page 12 for hookup examples.

4 Digital I/O Cards

About Digital I/O Cards

For digital output the AD824 uses optional mini YGDAI (Yamaha General Digital Audio Interface) cards, which are available in all the popular digital audio interconnect formats, including AES/EBU, ADAT, and Tascam TDIF-1.

The following digital I/O cards are currently available. See the Yamaha Professional Audio Web site at the following address for up-to-date news on mini YGDAI cards: <<http://www.yamaha.co.jp/product/proaudio/homeenglish/>>.

MY8-AT—ADAT

The MY8-AT card provides ADAT format digital I/O via two MultiChannel Optical Digital Interface connectors, and supports 16-, 20-, and 24-bit wordlengths.

MY8-AE—AES/EBU

The MY8-AE card provides AES/EBU format digital I/O via a 25-pin D-sub connector, and supports 16-, 20-, and 24-bit wordlengths.

MY8-TD—Tascam TDIF-1

The MY8-TD card provides Tascam TDIF-1 format digital I/O via a 25-pin D-sub connector, and supports 16-, 20-, and 24-bit wordlengths. A BNC connector is provided for wordclock output.

MY8-TD cards feature a device selector switch (EXT: 88/INT: 38) that should be set to match the device being connected. This should be set to “EXT: 88” when connecting a Tascam DA-88, or “INT: 38” when connecting a Tascam DA-38, DME32, or other device.

Card Specifications

The following table provides specifications for the AD824-compatible I/O cards.

Card	Format	In	Out	Wordlength	Connectors
MY8-AT	ADAT I/O	8	8	16, 20, 24	Optical x2
MY8-AE	AES/EBU I/O	8	8	16, 20, 24	25-pin D-sub (cable not included)
MY8-TD	Tascam TDIF-1 I/O	8	8	16, 20, 24	25-pin D-sub, BNC wordclock out

Installing I/O Cards

This section explains how to install mini YGDAI cards in the AD824.

- 1 Turn off the AD824.
- 2 Undo the two fixing screws and remove the slot cover, as shown below.

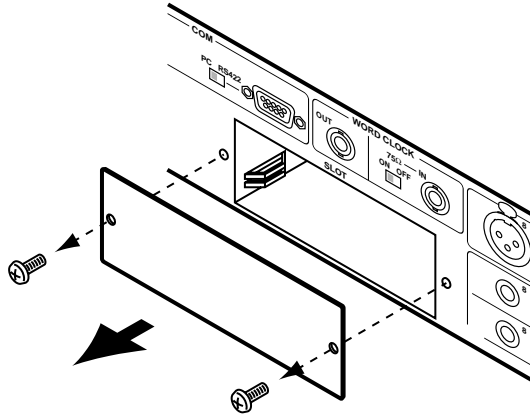

Keep the cover and fixing screws in a safe place for future use.

- 3 Insert the card between the guide rails and slide it all the way into the slot, as shown below. You may have to push firmly to plug the card into the AD824 connector.

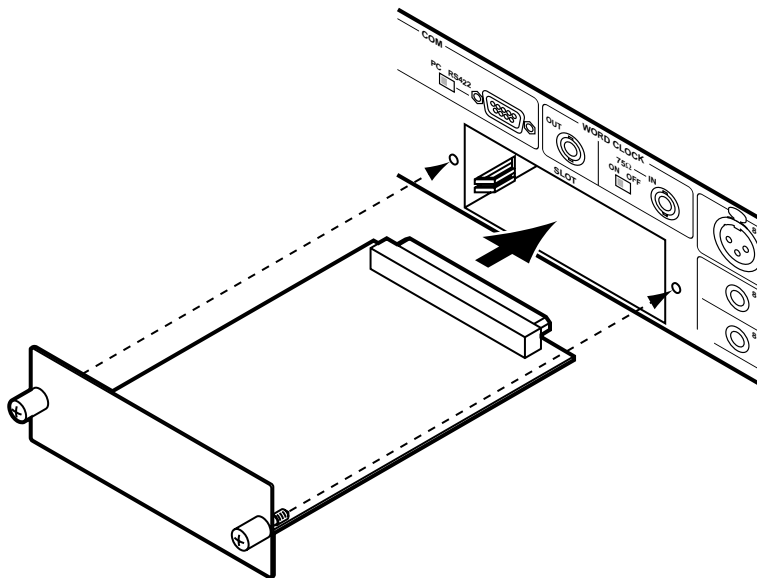

- 4 Secure the card using the attached thumbscrews. Do not leave the thumbscrews loose, as the card will not be grounded correctly.

5 Hookup Examples

In the following hookup examples, the “digital audio device” could be any device with a compatible AES/EBU or ADAT interface, including the following Yamaha products with the necessary I/O cards installed: DME32 Digital Mixing Engine, 02R Digital Recording Console, 03D Digital Mixing Console, 01V Digital Mixing Console, or D24 Digital Multitrack Recorder.

Basic AES/EBU Connection

This example shows how the AD824 can be connected to a digital audio device with an AES/EBU interface by using an MY8-AE I/O card and a 25-pin D-sub AES/EBU connecting cable. Either device could be used as the word-clock master.

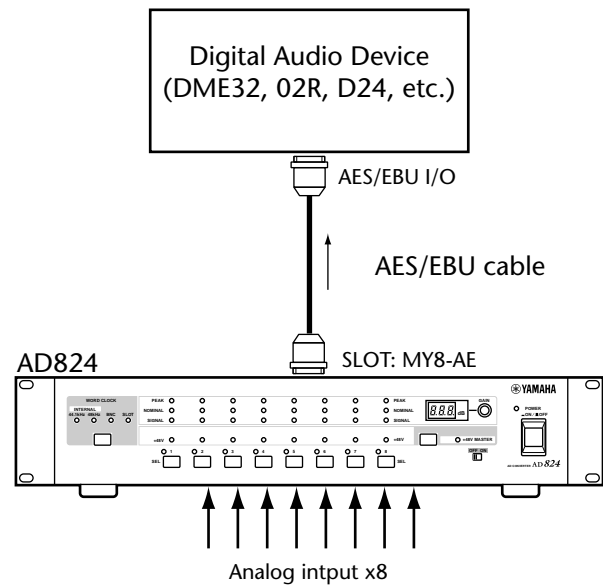

Basic ADAT Connection

This example shows how the AD824 can be connected to a digital audio device with an ADAT interface by using a MY8-AT I/O card and standard ADAT connecting cable. The AD824 is the wordclock master. In order to use the digital audio device as the wordclock master, its wordclock signal would need to be fed to the AD824 using the SLOT ADAT IN or BNC WORD CLOCK IN.

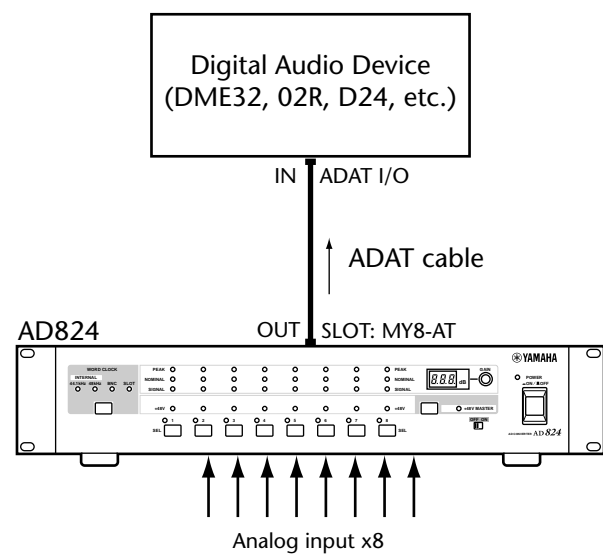

AES/EBU Connection with Splitter Cable

This example shows how both an AD824 and DA824 can be connected to a digital audio device with a single AES/EBU interface by using MY8-AE I/O cards and a custom AES/EBU splitter cable. Pin wiring details for the AES/EBU interface are supplied with the MY8-AE I/O card. The digital audio device is the wordclock master, with the AD824 receiving its wordclock via a BNC connection, the DA824, via its slot input.

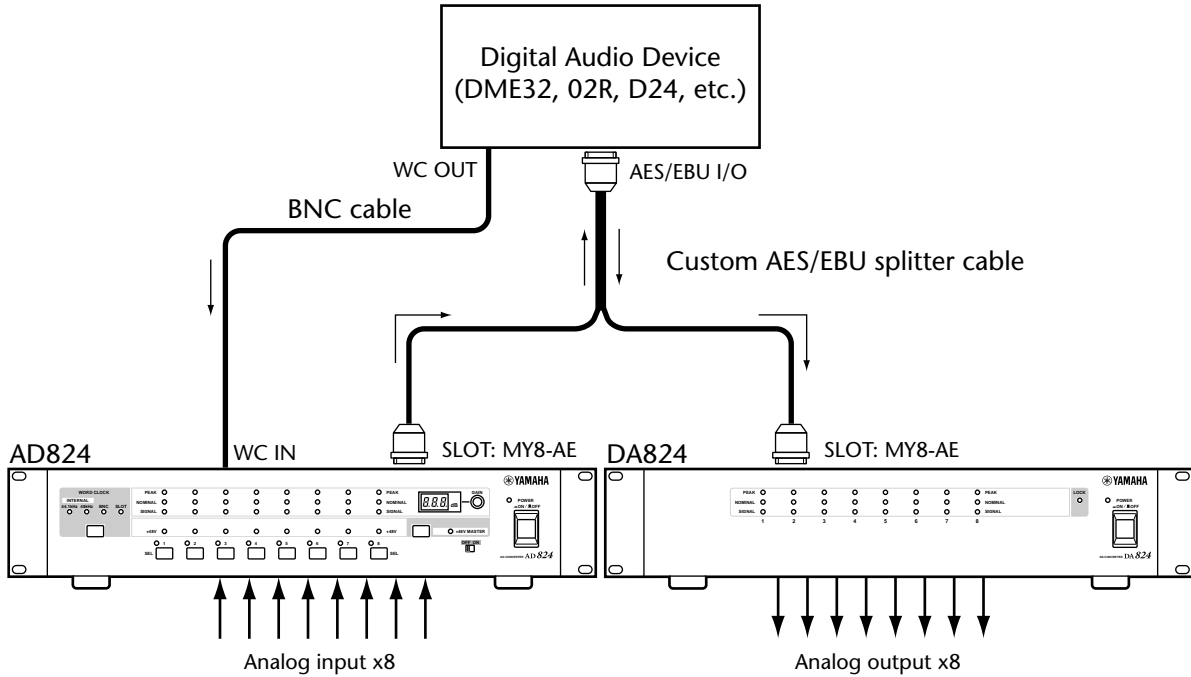

Dual ADAT Connection

This example shows how both an AD824 and DA824 can be connected to a digital audio device with standard ADAT I/O by using MY8-AT I/O cards and standard ADAT connecting cables. The digital audio device is the wordclock master, with the AD824 receiving its wordclock via a BNC connection, the DA824, via its slot input.

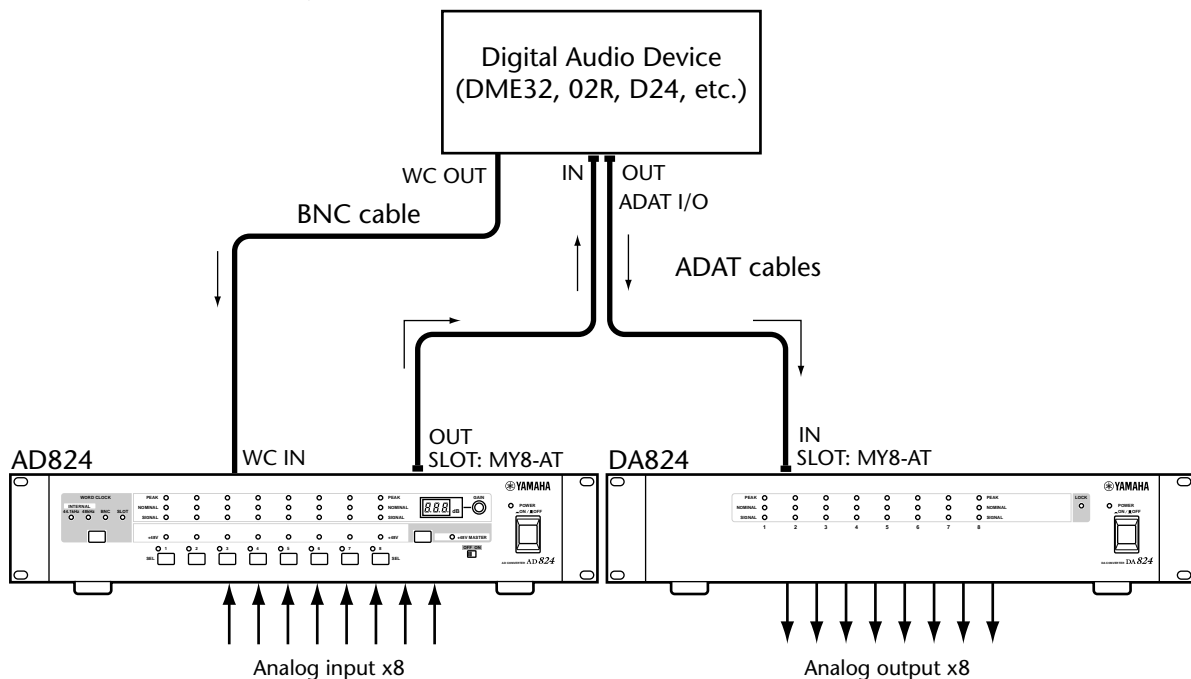

Insert Connection

This example shows how analog outboard equipment can be patched into each channel by using the INSERT IN and OUT 1/4" TRS phone jacks. The insert point on each channel is located between the head amplifier and A/D converter. The signal level indicators are located after the INSERT IN connector.

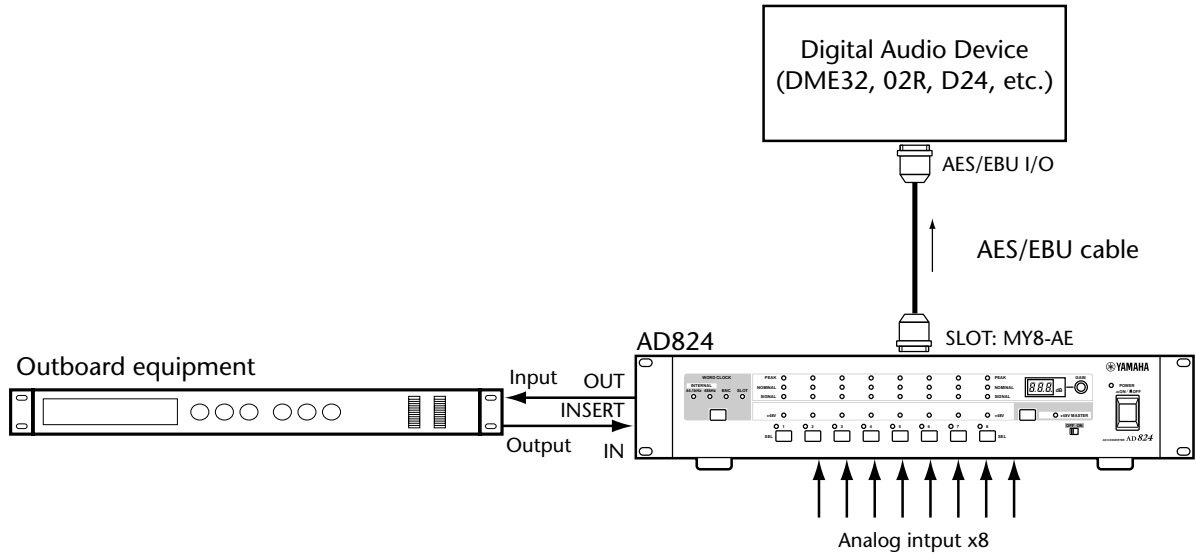

Personal Computer Connection

This example shows how a personal computer can be connected to the AD824 for remote control. The computer is connected to the AD824's COM PC/RS422 port, and the COM PC/RS422 switch is set to PC.

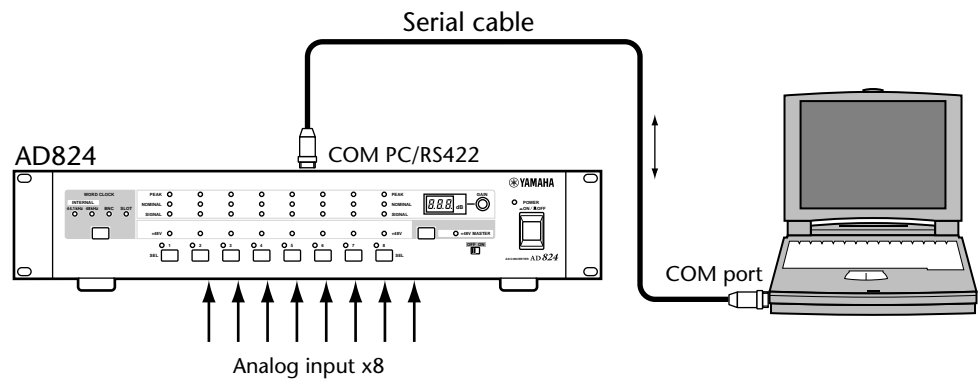

Yamaha DME32 Connection

The following example shows how the AD824 can be connected to the Yamaha DME32 Digital Mixing Engine for remote control. Channel gain and phantom power can be remotely controlled and recalled from the DME32, which features Gain Trimmer components especially for use with the AD824. The COM PC/RS422 port on the AD824 is connected to the COM port on the DME32. The AD824's COM PC/RS422 switch is set to RS422. The DME32 is the wordclock master, with the AD824 receiving its wordclock via a BNC connection, the DA824, via its slot input.

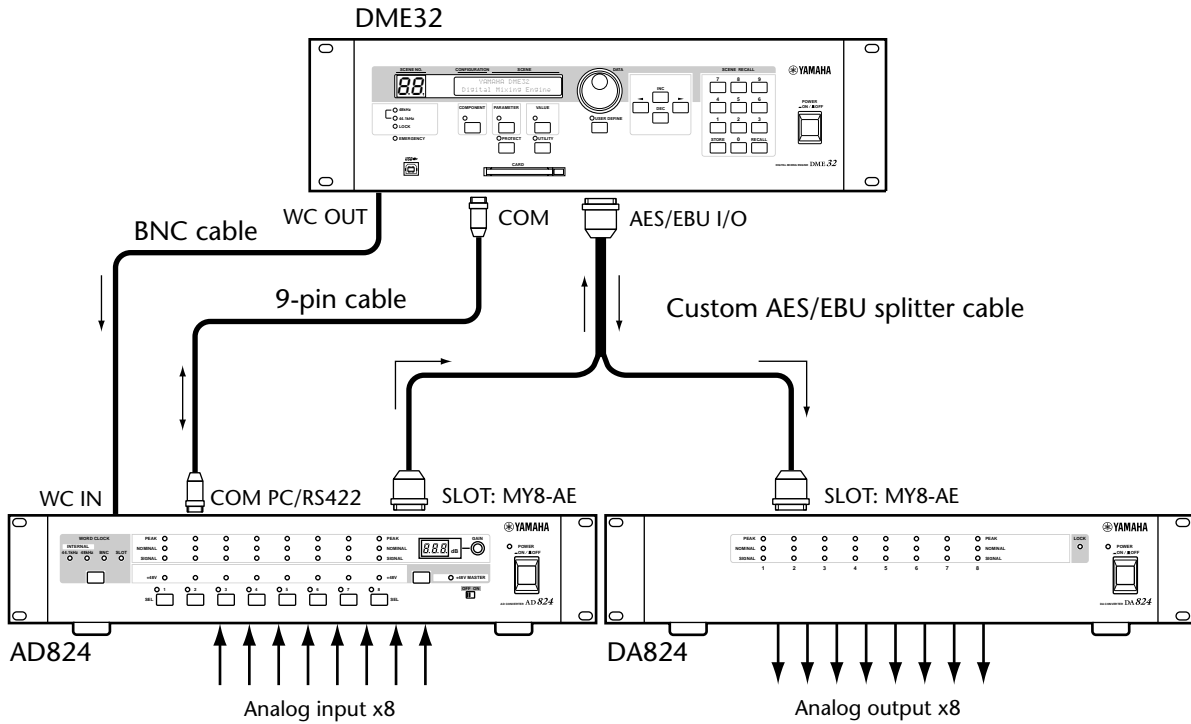

Multiple AD824 Connection

The next example shows how the AD824 COM ports can be used to connect several AD824s in combination with a DME32. The COM PC/RS422 port on the AD824 #1 is connected to the COM port on the DME32, while the COM RS422 port on AD824 #1 is connected to the COM PC/RS422 port on AD824 #2. The COM PC/RS422 switches on both AD824s are set to RS422. The DME32 is the wordclock master and both the AD824s receive their wordclocks via their SLOT inputs.

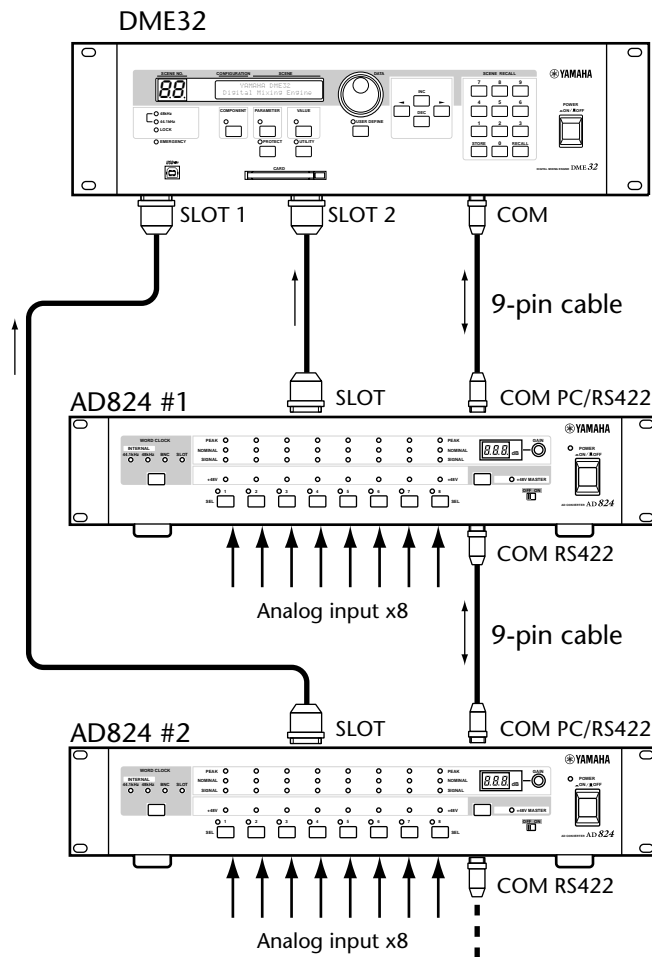

6 Wordclocks

About Wordclocks

For correct operation and analog-to-digital conversion, it's essential that the AD824 is wordclock locked to the digital audio device connected to its SLOT output. The AD824 can generate a wordclock signal internally at either 44.1 kHz or 48 kHz, so it could be used as the wordclock master, in which case the device connected to the SLOT would be used as a wordclock slave. Alternatively, the AD824 can lock to an external wordclock signal derived from its SLOT, or a wordclock signal received at the WORD CLOCK IN connector.

See page 5 for information on selecting the wordclock source.

Wordclock Hookup Examples

In this example, the AD824 sources its wordclock signal from its SLOT. Note that the AD824 is transmitting digital audio to the digital audio device and deriving a wordclock signal from it all down the same cable. This works okay with AES/EBU and Tascam TDIF-1 digital connections, because a single cable is all that's required to transmit and receive digital audio. With the ADAT format, however, separate optical cables are used to transmit and receive, so in order to transmit digital audio and derive a wordclock signal, both the ADAT IN and OUT on the AD824 must be connected to the digital audio device.

In this example, the AD824 sources its wordclock signal from its BNC WORD CLOCK IN connector.

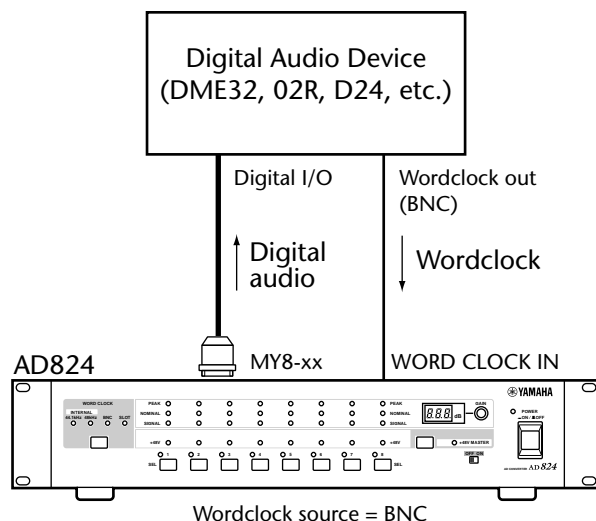
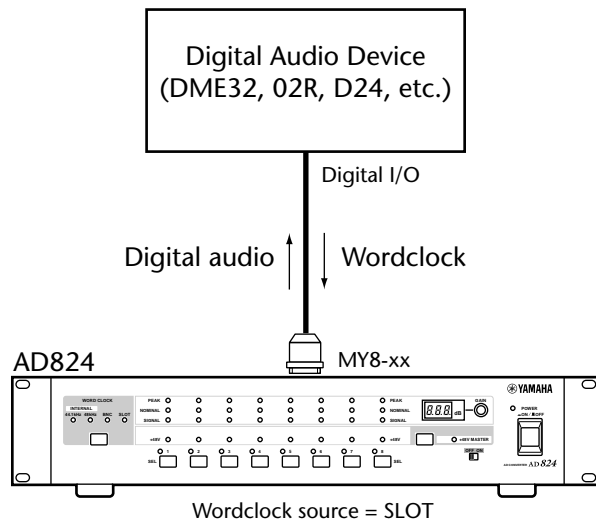

Wordclock Termination

For correct and reliable operation, wordclock signals distributed via BNC cables must be terminated correctly. Termination is typically applied at the last device, although it depends on the distribution method being used. The AD824's WORD CLOCK 75Ω ON/OFF switch allows the AD824 to be connected in a variety of ways. The following examples show three ways in which wordclock signals can be distributed and how termination should be applied in each case.

Wordclock Distribution Box

In this example, a dedicated wordclock distribution box is used to supply a wordclock signal to each device individually. Termination is applied at each device.

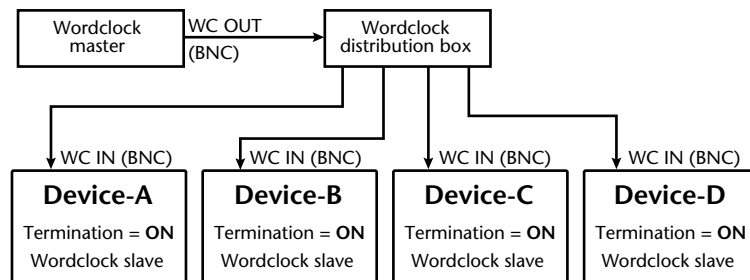

Bus Distribution

In this example, the wordclock signal is distributed via a common line. Termination is applied at the last device only.

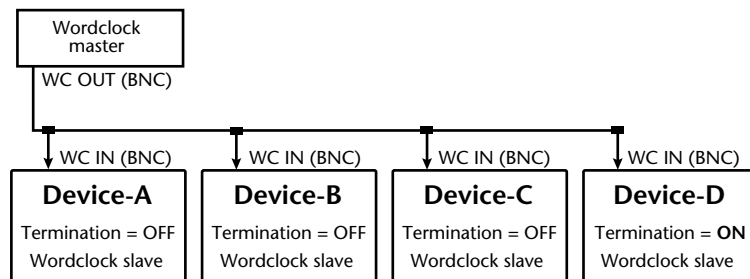

Daisy Chain Distribution

In this example, the wordclock signal is distributed in a “daisy-chain” fashion, with each device feeding the wordclock signal on to the next. Termination is applied at the last device only. This method of distribution is not recommended for larger systems.

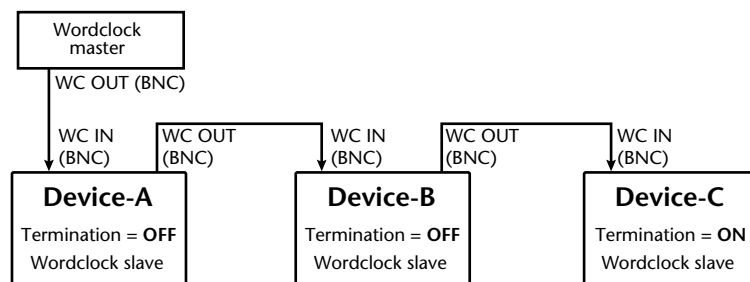

Appendix

Error Messages

The AD824 performs several diagnostic checks when it's turned on. If a problem is detected, one of the following error codes appears briefly on the GAIN display.

E1—Internal backup-battery voltage low.

E2—Internal memory data corrupt.

E3—Internal backup-battery voltage low and internal memory data corrupt.

Specifications

Sampling rate	MY8-AE, MY8-TD	39.69–50.88 kHz
	MY8-AT	41.013–50.88 kHz
AD conversion resolution	24-bit linear, 128-times oversampling	
Frequency response	–1.5, +1 dB, 20 Hz–20 kHz, GAIN +10 dB	
	–3, +1 dB, 20 Hz–20 kHz, GAIN –62 dB	
Dynamic range ¹	110 dB (typical), GAIN +10 dB	
Gain error	±1 dB @ 1 kHz, GAIN –62 dB to +10 dB	
THD ²	0.1%, 4 dB output @ 20 Hz–20 kHz, GAIN –62 dB	
	0.05%, full scale output @ 1 kHz, GAIN –62 dB	
	0.05%, 4 dB output @ 20 Hz–20 kHz, GAIN +10 dB	
	0.01%, full scale output @ 1 kHz, GAIN +10 dB	
Hum & noise level ¹	–92 dB (typical), $R_s = 150 \Omega$, GAIN +10 dB	
	–62 dB, $R_s = 150 \Omega$, GAIN –62 dB	
Equivalent input noise ¹	–128 dB, $R_s = 150 \Omega$, GAIN –62 dB	
Crosstalk	–70 dB between adjacent channels @ 1 kHz	
Signal delay	0.85 ms (analog input to digital output, $f_s = 48$ kHz)	
Phantom power	+48 V	
Channel indicators	PEAK	3 dB below full scale
	NOMINAL	14 dB below full scale
	SIGNAL	34 dB below full scale
	+48V	Phantom power on/off
	SEL	Channel select
Other indicators	Wordclock	44.1kHz, 48kHz, BNC, SLOT
	+48V MASTER	Phantom power master on/off
	POWER	Power on/off
Gain display	3-digit, 7-segment LED	

Power requirements	U.S.A. & Canada 120 V AC, 60 Hz Europe 230 V AC, 50 Hz
Power consumption	50 W
Dimensions (W × H × D)	480 × 97.5 × 377.6 mm (18.9 × 3.84 × 14.86 inches)
Weight	8.5 kg (18.7 lbs)
Free-air operating temperature	10° C to 35° C (50° F to 95° F)
Storage temperature	–20° C to 60° C (–4° F to 140° F)
Relative humidity	10%–95%
Power cord length	1.9 m
Supplied accessories	<i>Owner's Manual</i> , 9-pin D-sub crossed cable (1.5m)
Options	MY8-AT, MY8-TD, MY8-AE mini YGDAI I/O cards

1. Measured with a 6 dB/octave filter at 12.7 kHz; equivalent to a 20 kHz filter with infinite dB/octave attenuation.
 2. Measured with a 6 dB/octave filter @ 80 kHz.
- * Where dB represents a specific voltage, 0 dB is referenced to 0.775 V rms.

Analog Input

Connection	GAIN	Actual Load Impedance	For Use with Nominal	Input Level		Connector
				Nominal	Max. before clip	
INPUT 1–8 ¹	–62 dB	3k Ω lines	50–600 Ω mics & 600 Ω lines	–62 dB (615 μV)	–48 dB (3.08 mV)	XLR-3-31 type (balanced) ²
	+10 dB			+10 dB (2.45 V)	+24 dB (12.28 V)	
INSERT IN 1–8		10k Ω	600 Ω lines	+10 dB (2.45 V)	+24 dB (12.28 V)	TRS phone jack (balanced) ³

1. 24-bit linear, 128-times oversampling A/D converters.
 2. XLR-type connectors are electronically balanced (pin 1 = ground, pin 2 = hot, pin 3 = cold).
 3. TRS phone jacks are electronically balanced (tip = hot, ring = cold, sleeve = ground).
- * Where dB represents a specific voltage, 0 dB is referenced to 0.775 V rms.

Analog Output

Connection	Actual Source Impedance	For Use with Nominal	Output Level		Connector
			Nominal	Max. before clip	
INSERT OUT 1–8	150 Ω	10k Ω lines	+10 dB (2.45 V)	+24 dB (12.28 V)	TRS phone jack (balanced) ¹

1. TRS phone jacks are electronically balanced (tip = hot, ring = cold, sleeve = ground).
- * Where dB represents a specific voltage, 0 dB is referenced to 0.775 V rms.

Digital I/O

Connection	Format	Level/Impedance	Connector
COM PC/RS422	—	RS232C/RS422	9-pin D-sub (male)
COM RS422	—	RS422	9-pin D-sub
WORD CLOCK IN	—	TTL, 75Ω (ON/OFF)	BNC
WORD CLOCK OUT	—	TTL, 75Ω	BNC
SLOT	mini YGDAI	—	—

Dimensions

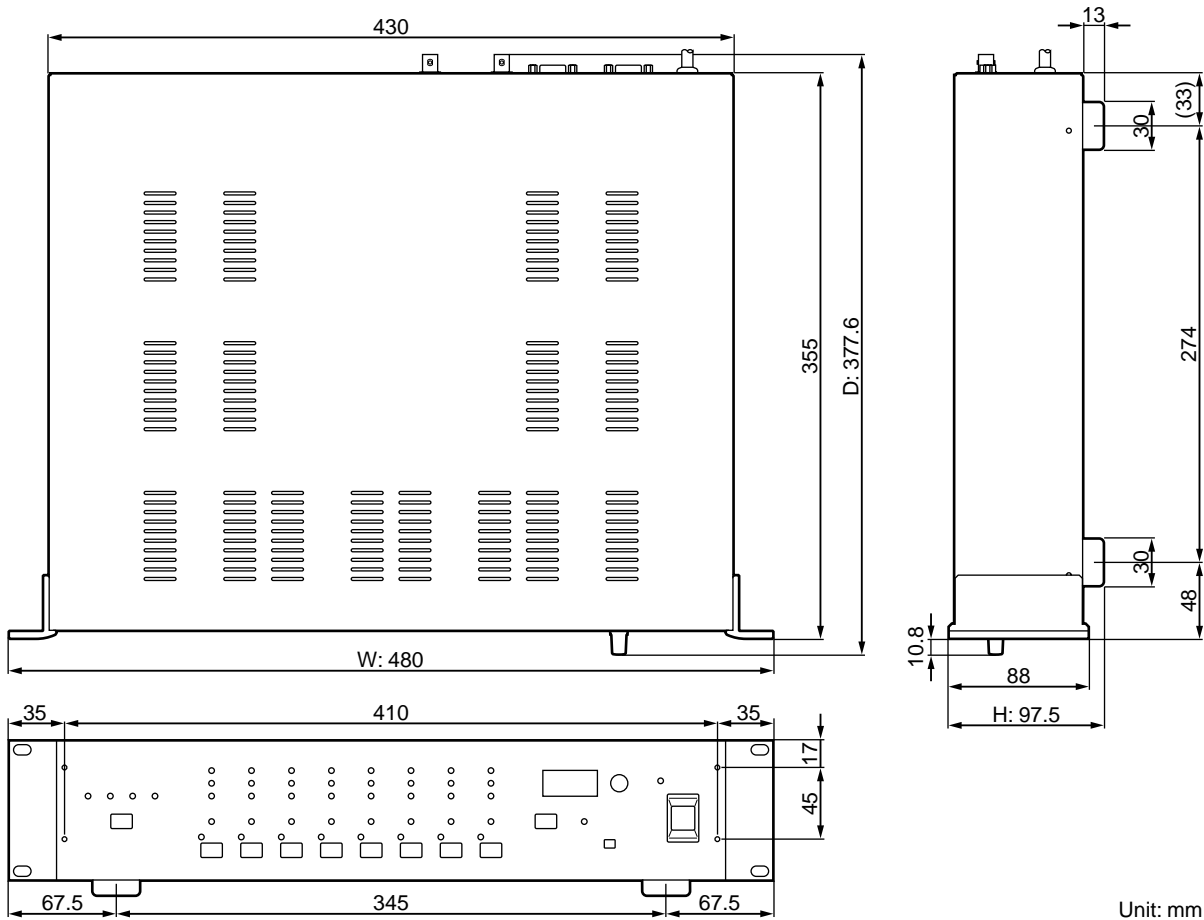

Specifications and external appearance subject to change without notice.

For European Model

Purchaser/User Information specified in EN55103-1 and EN55103-2.

Inrush Current: 10A

Conformed Environment: E1, E2, E3 and E4